

# SJZ Metalsin Tech Co Ltd

AWWA C515 NRS gate valves with grooved ends & a top mounting flange for post indicator or extended stem.

## Product Drawing

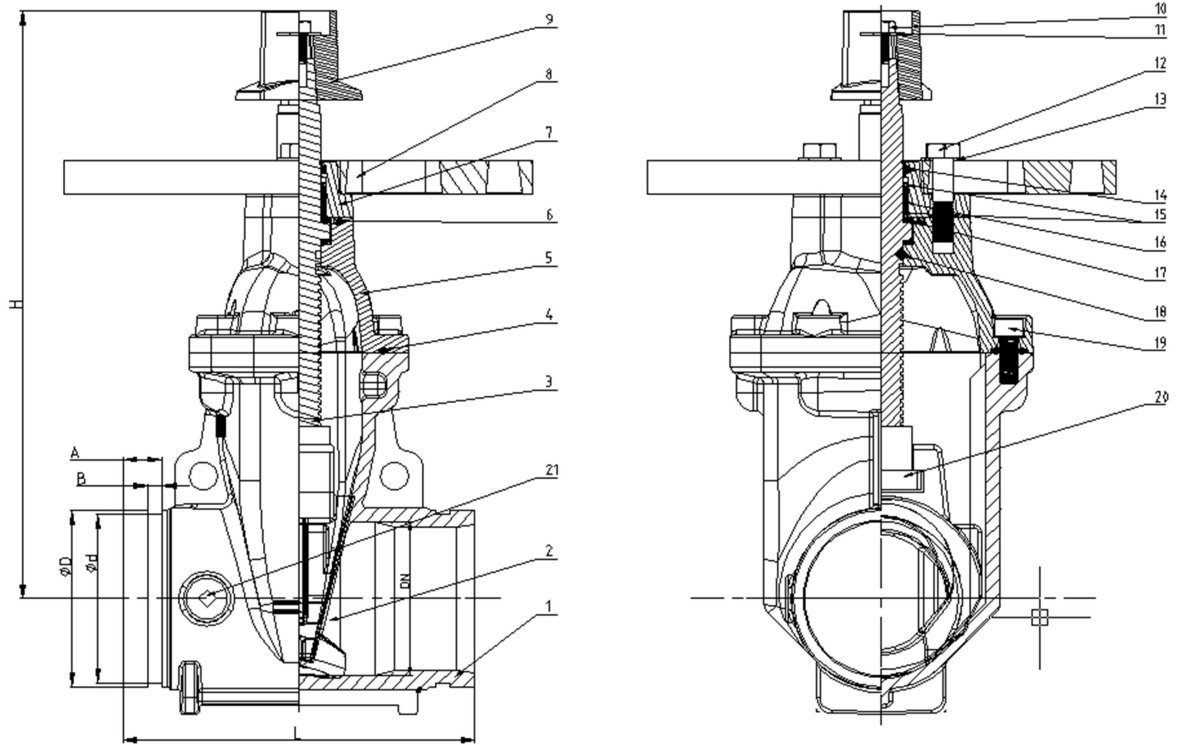

## Dimensions

Size		Dimensions(mm)					
inch	mm	L	H	OD	d	A	B
4"	100	229	395	114.3	110.08	15.88	9.52
5"	125	254	432	141.3	137.03	15.88	9.52
6"	150	267	475	168.3	163.96	15.88	9.52
8"	200	292	585	219.1	214.40	19.05	11.13
10"	250	330	656	273.0	268.28	19.05	12.70
12"	300	356	751	323.9	318.29	19.05	12.70

## Flow rates

DN	DN100	DN125	DN150	DN200	DN250	DN300
Kv	162.8	254.4	366.3	651.1	1017.4	1456

## Material Specifications

Part No.	Part	Standard Specification	Options
1	Valve Body	ASTM A536,65-45-12	
2	Resilient Wedge disc	ASTM A536,65-45-12+EPDM	
3	Stem	Stainless Steel	AISI 304、 AISI 316、 AISI 431
4	Bonnet Gasket	EPDM	
5	Bonnet	ASTM A536,65-45-12	
6	O-Ring	NBR	EPDM
7	Gland	ASTM A536,65-45-12	
8	Post Flange	ASTM A536,65-45-12	
9	Square Operating Nut	ASTM A536,65-45-12	
10	Bolt	Carbon Steel Zinc Plated	AISI 304、 AISI 316、
11	Flat Washer	Carbon Steel Zinc Plated	AISI 304、 AISI 316、
12	Bolt	Carbon Steel Zinc Plated	AISI 304、 AISI 316、
13	Flat Washer	Carbon Steel Zinc Plated	AISI 304、 AISI 316、
14	Ring Wiper	EPDM	NBR
15	O-Ring	NBR	EPDM
16	Axis guide	Brass Hpb59-1	
17	Washer	CW617N	
18	O-Ring	NBR	EPDM
19	Bolt	Carbon Steel Zinc Plated	
20	Wedge nut	Brass Hpb59-1	
21	NPT Pipe Plug	ASTM B584-06a C89833	