

AWWA C515 NRS gate valves with mechanical-joint ends & a top mounting flange for post indicator or extended stem.

Product Drawing

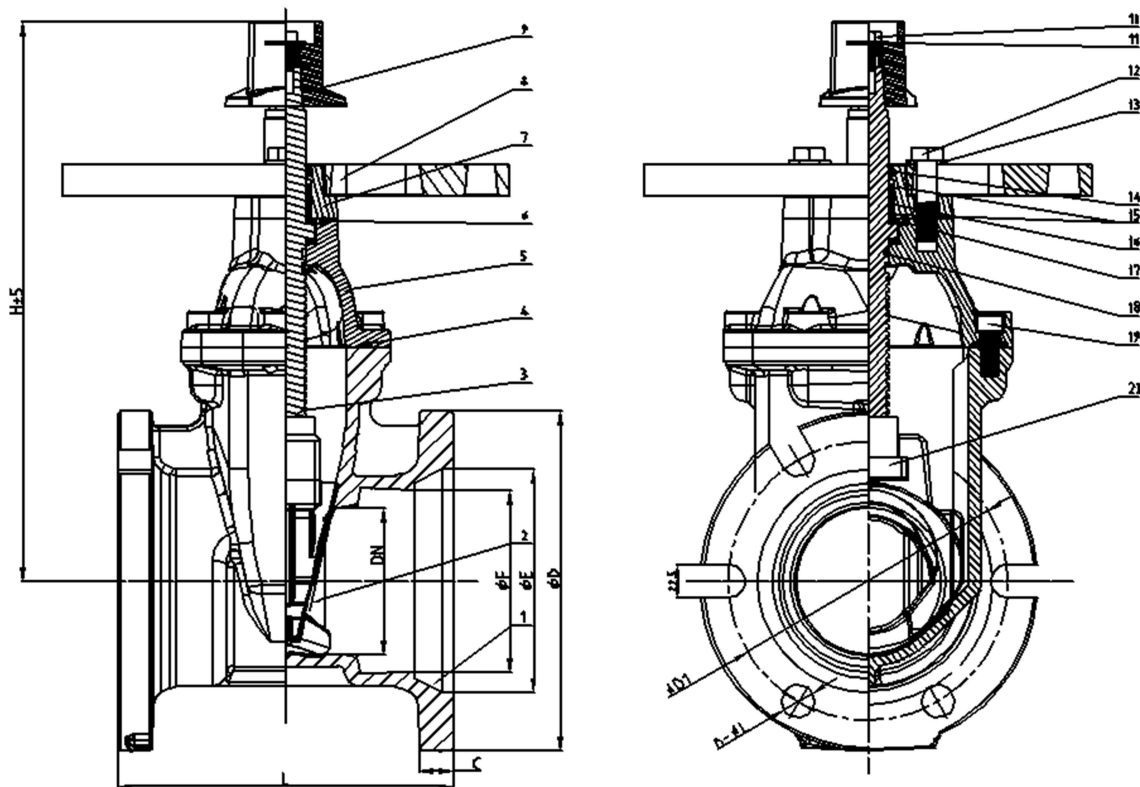

Dimensions

DN		Dimensions(mm)							
inch	mm	L	H±5	øD	øD1	øE	øF	C	n-øL
4"	100	229	355	232	190.5	152.9	124.5	19.1	4-ø22.2
6"	150	292	448	282	241.3	206.2	177.8	19.1	6-ø22.2
8"	200	318	548	340	298.5	260.9	232.4	22.2	6-ø22.2
10"	250	375	626	397	355.6	313.4	284.4	23.8	8-ø22.2
12"	300	378	722	454	412.7	366.7	337.8	25.4	8-ø22.2

Flow rates

DN	DN100	DN150	DN200	DN250	DN300
Kv	162.8	366.3	651.1	1017.4	1456

SJZ Metalsin Tech Co Ltd

Material Specification

Part No.	Part	Standard Specification	Options
1	Valve Body	ASTM A536, 65-45-12	
2	Resilient Wedge disc	ASTM A536, 65-45-12+EPDM	
3	Stem	AISI 420	AISI 304、 AISI 316、 AISI 431
4	Bonnet Gasket	EPDM	
5	Bonnet	ASTM A536, 65-45-12	
6	O-Ring	NBR	EPDM
7	Gland	ASTM A536, 65-45-12	
8	Indicator Post Flange	ASTM A536, 65-45-12	
9	Square Operating Nut	ASTM A536, 65-45-12	
10	Bolt	Carbon Steel Zinc Plated	AISI 304、 AISI 316、
11	Flat Washer	Carbon Steel Zinc Plated	AISI 304、 AISI 316、
12	Nut	Carbon Steel Zinc Plated	
13	Flat Washer	Carbon Steel Zinc Plated	AISI 304、 AISI 316、
14	Ring Wiper	EPDM	NBR
15	O-Ring	NBR	EPDM
16	Axis guide	Brass HPb59-1	
17	Washer	Brass HPb59-1	
18	O-Ring	NBR	EPDM
19	Bolt	Carbon Steel Zinc Plated	AISI 304、 AISI 316、
20	Wedge nut	Brass HPb59-1	